

**RacingSparrow RG65**

[www.racingsparrow.co.nz](http://www.racingsparrow.co.nz)

**VERSION v1.0**

The rig stands at 942mm off the deck. You could consider this a B-rig as the class rules permit a mast that is 1100mm from the deck. With a maximum sail area of 2250 cm<sup>2</sup>. This boat is designed for heavy wind sailing, this gives it a wide range of conditions with one set of sails. Different sized rigs can be added by the individual who wants to take it a step further, which is encouraged by the designer.

The hull must be 650mm or shorter. The hull must have a bowbumper for racing.

These plans should produce a race ready boat. For detailed measurement rules and information visit:

[www.RG65.com](http://www.RG65.com)

Note: these plans are very new and untested, at your own risk. But it should be sweet! and sail like a rocket. cheers. Bryn.

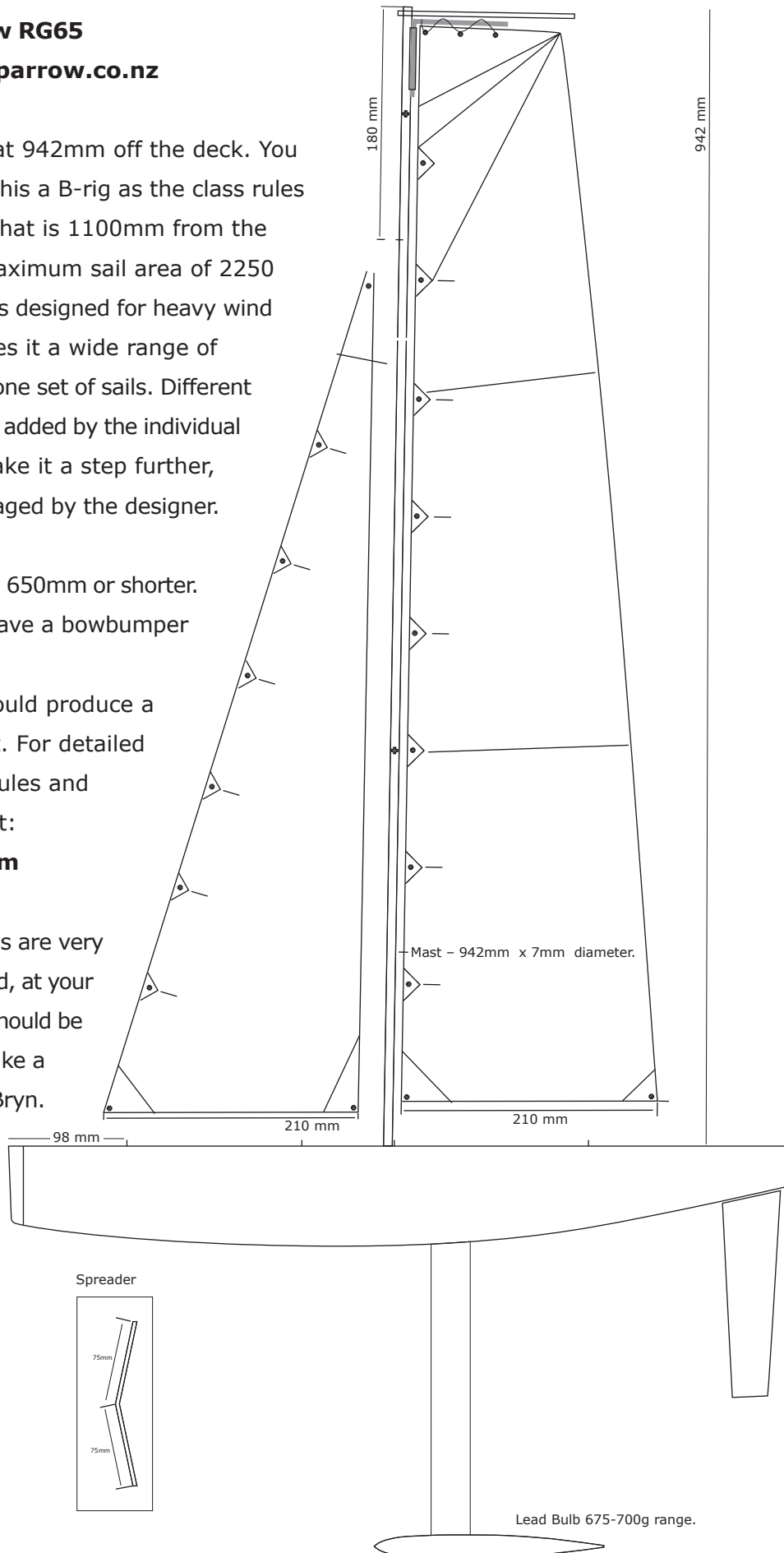

**Boat Design: RacingSparrow RG65**

**Not to Scale**

©Designer: Bryn Heveldt. [www.racingsparrow.co.nz](http://www.racingsparrow.co.nz) TRIAL VERSION v1.0

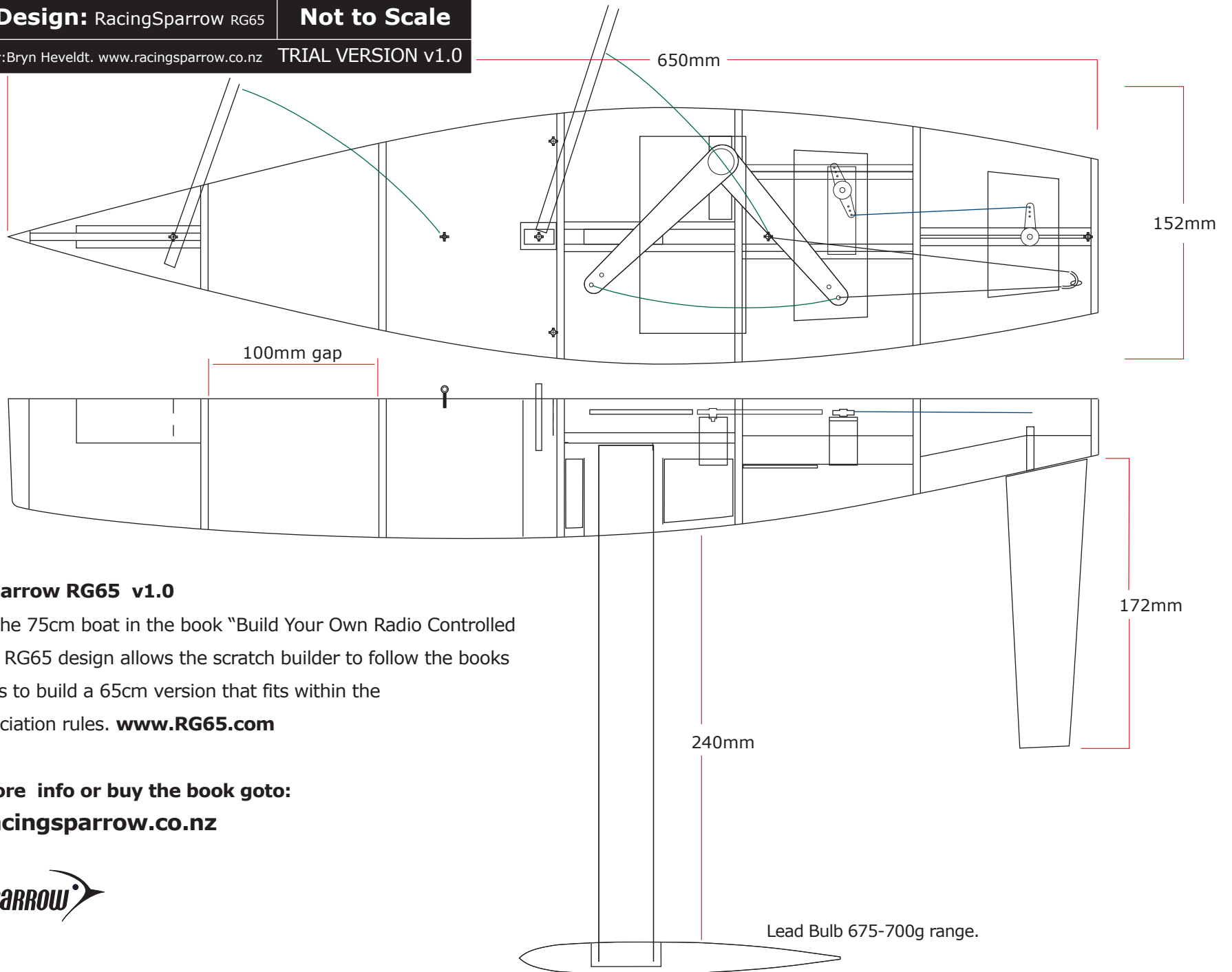

**RacingSparrow RG65 v1.0**

Based on the 75cm boat in the book "Build Your Own Radio Controlled Yacht" this RG65 design allows the scratch builder to follow the books instructions to build a 65cm version that fits within the RG65 association rules. [www.RG65.com](http://www.RG65.com)

To get more info or buy the book goto:  
[www.racingsparrow.co.nz](http://www.racingsparrow.co.nz)



Lead Bulb 675-700g range.



**RacingSparrow RG65**  
**www.racingsparrow.co.nz**  
**VERSION v1.0**

This is the swing rig setup.

For detailed measurement rules and information visit:

**www.RG65.com**

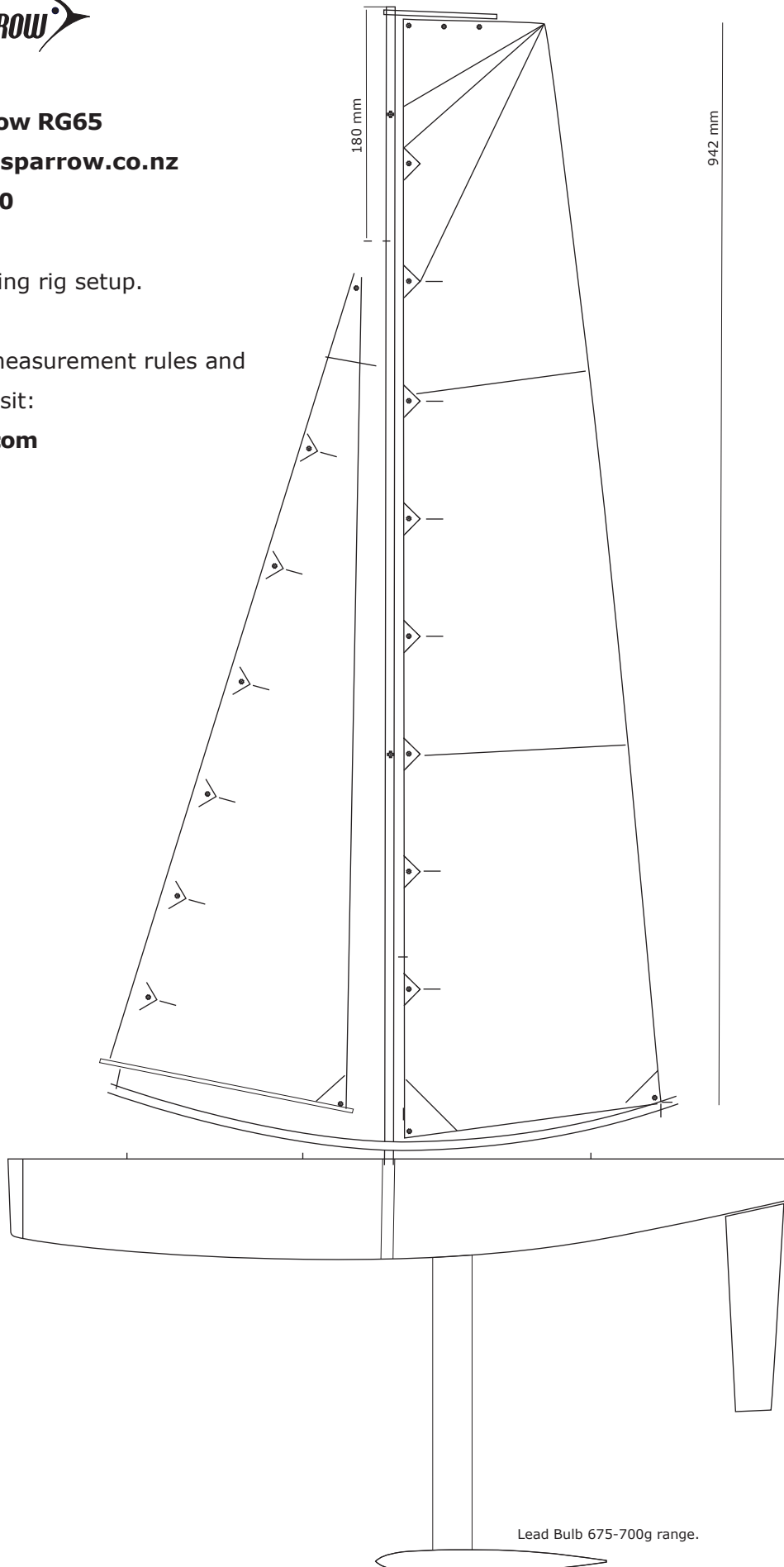

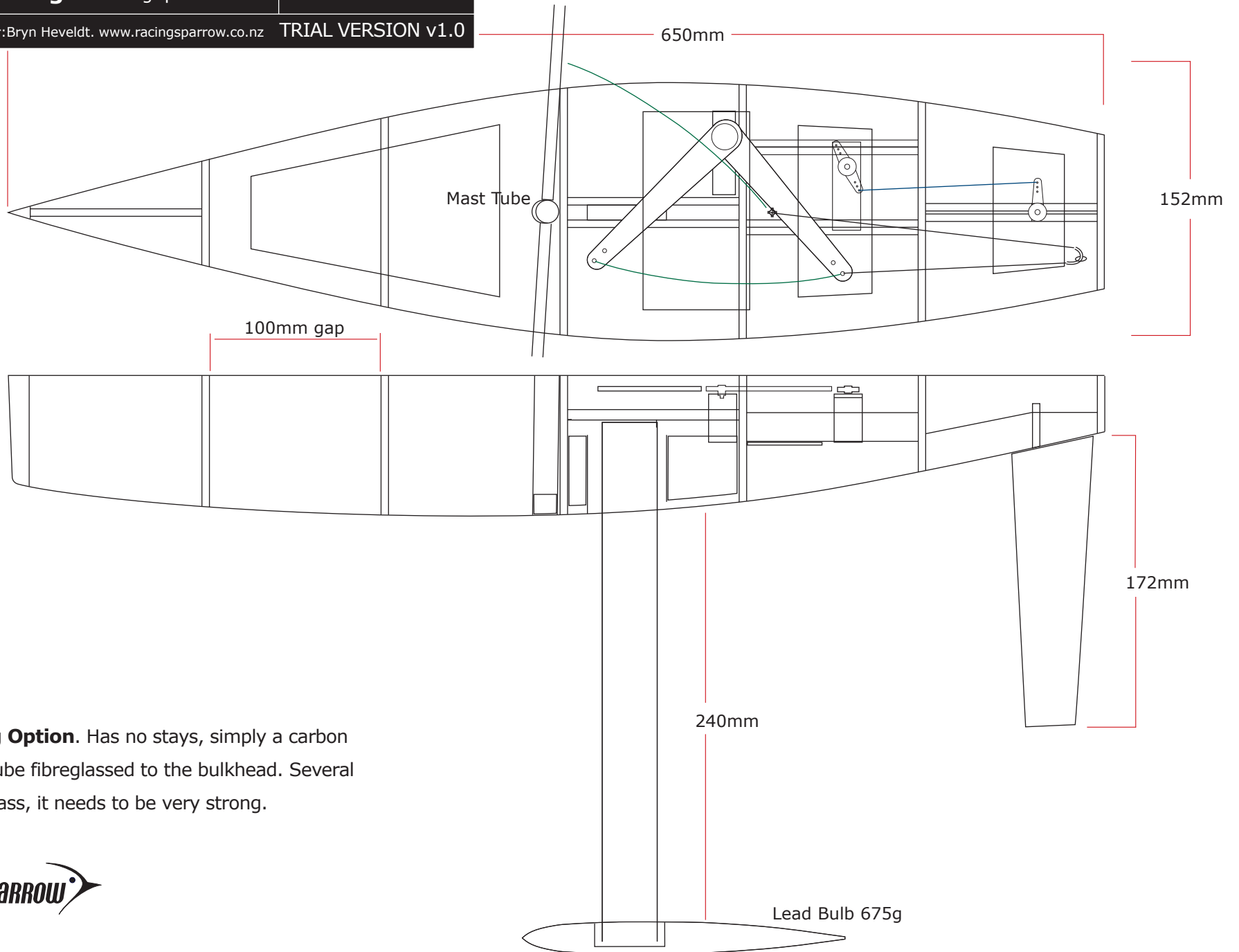

**Swing Rig Option.** Has no stays, simply a carbon or plastic tube fibreglassed to the bulkhead. Several layers of glass, it needs to be very strong.



**RacingSparrow RS750**

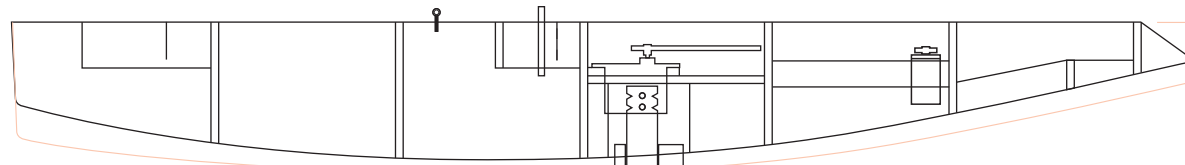
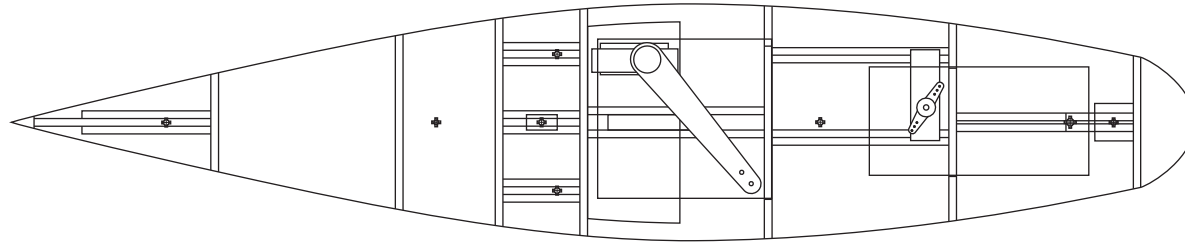

**RacingSparrow RG65**

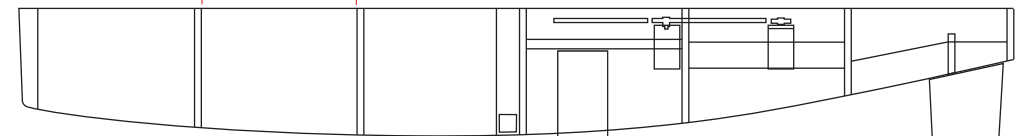
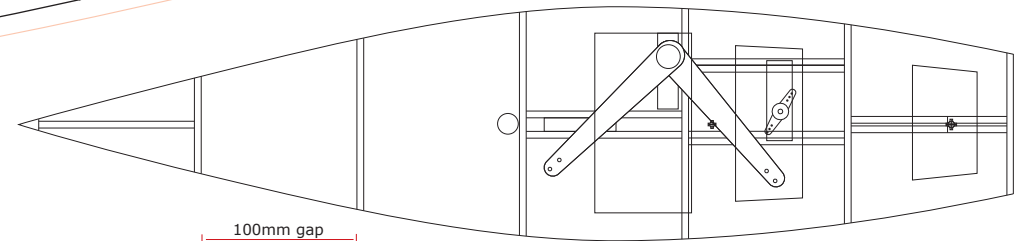

**RacingSparrow RG65**

**VERSION v1.0**

- \*Same width(Beam)
- \*Same depth
- \*Similar keel depths
- \*No sloped back (transom)
- \*Fuller bow sections
- \*Mast stepped further back
- \*Side stays further back and closer to the gunnels, glued to bulkhead - no need for half bulkhead C2.
- \*bulb weight not tested. this is a trial design.

Tuesday 17 November 2009

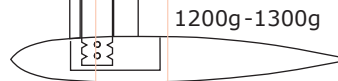

This faint pink line indicates the difference in hull shapes. I've scaled the 65 up to 75 and overlaid the outlines. You can see there's more buoyancy in the front and the back. The keel and mast step back a cm or so. The 65's rudder would also be a bit longer than a 750 to scale. This allows for the similar electrics layout as in the book, simply change measurements hatch positions need to change. These plans show the option to have conventional wire stays or a swinging rig supported by a tube in the hull.

100mm gap

Lead Bulb 675-700g

When these plans are printed the box around this text should measure 100x20mm. If it doesn't try altering the print settings and scale the printing to 102% for example.

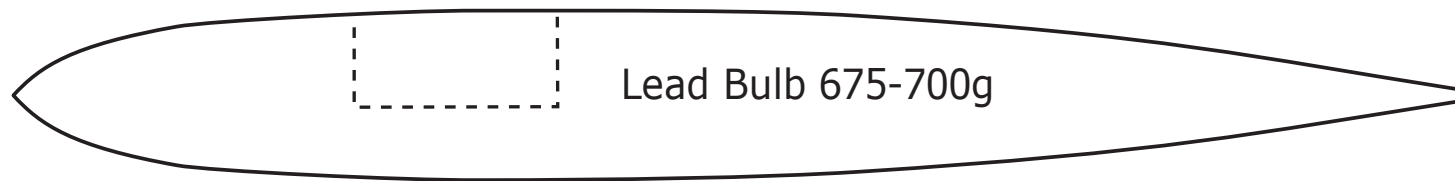
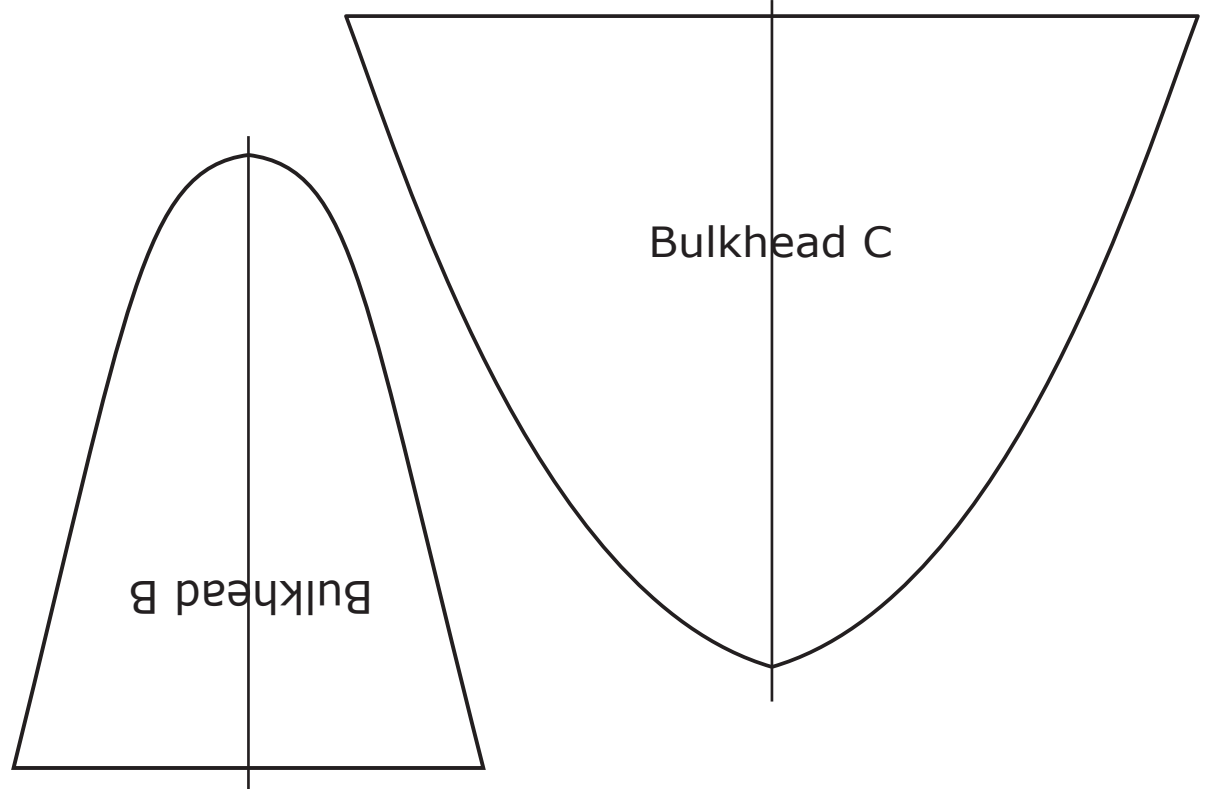
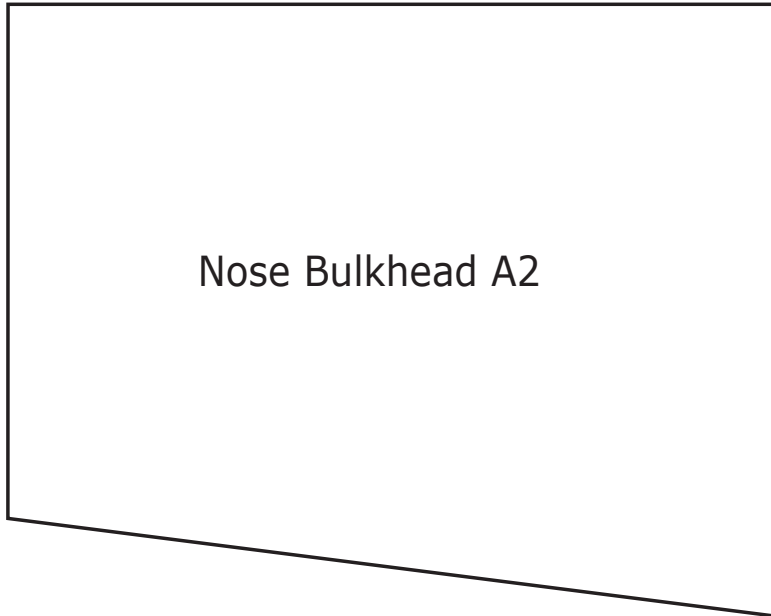

When these plans are printed the box around this text should measure 100x20mm. If it doesn't try altering the print settings and scale the printing to 102% for example.

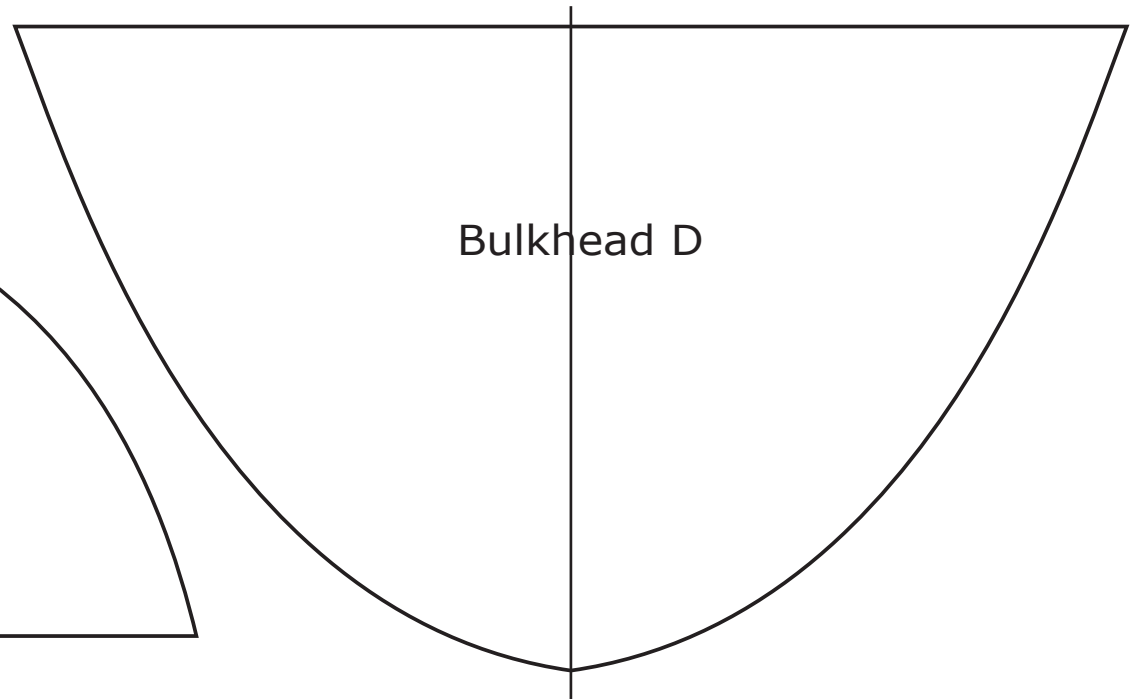
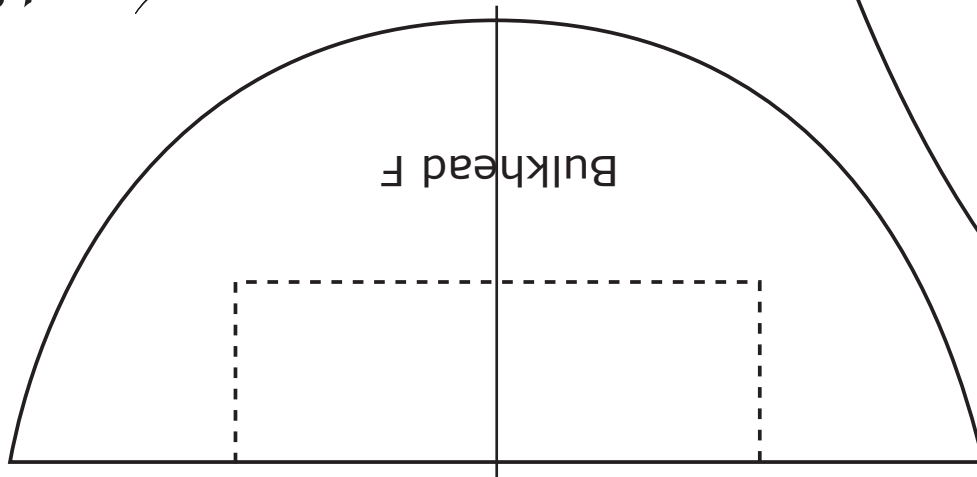
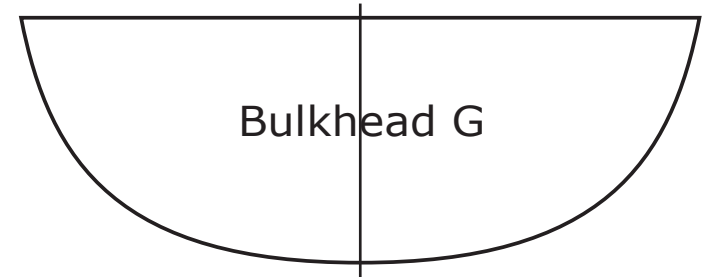
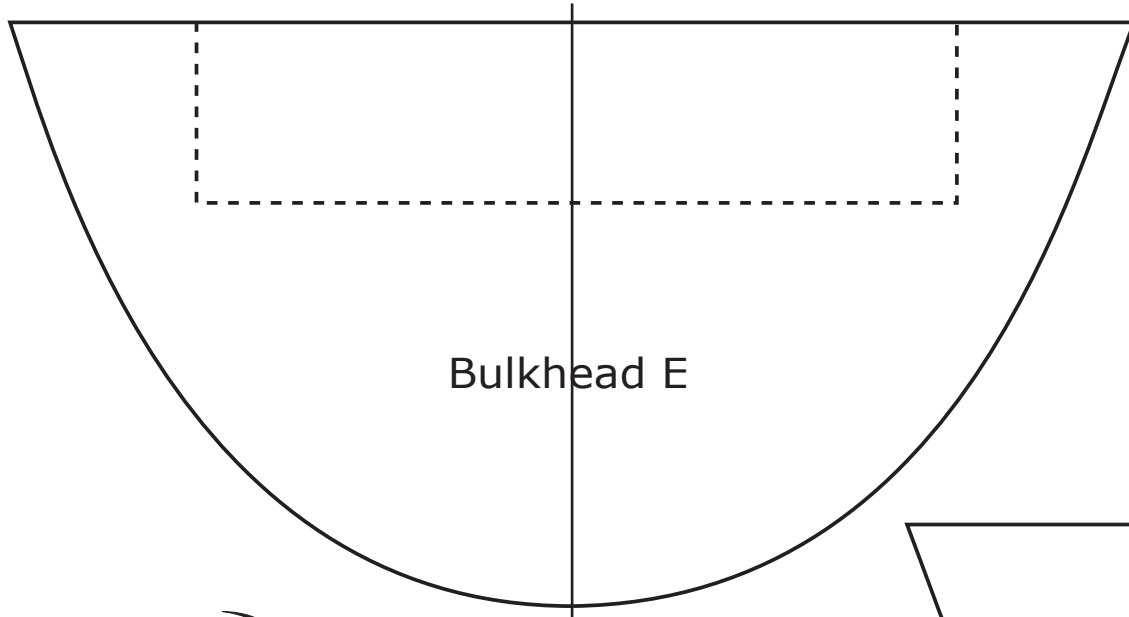

When these plans are printed the box around this text should measure 100x20mm. If it doesn't try altering the print settings and scale the printing to 102% for example.

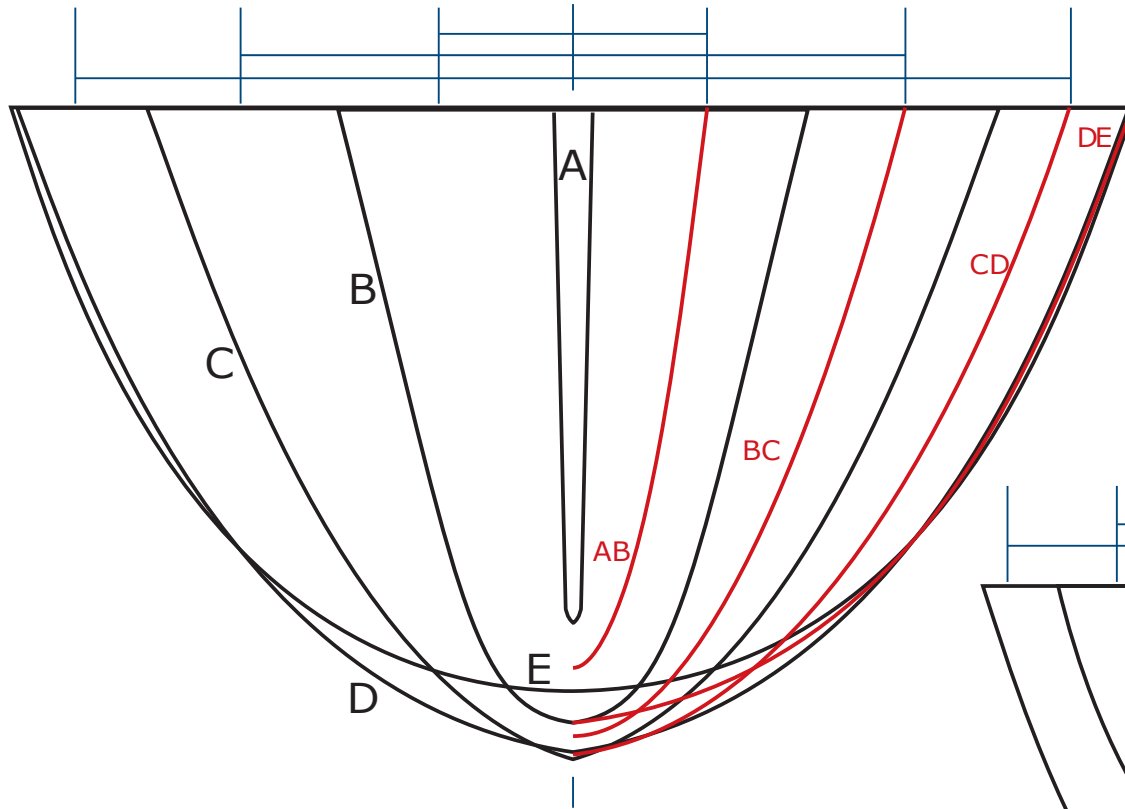

The red lines show a secondary set of bulkheads. These go between each of the main bulkheads. The lettering system is quite straight forward. The extra bulkheads are not required for the build but will help you create a more accurate planked hull.

Once the boat is fibreglassed any excess bulkheads can be removed to lighten the hull.

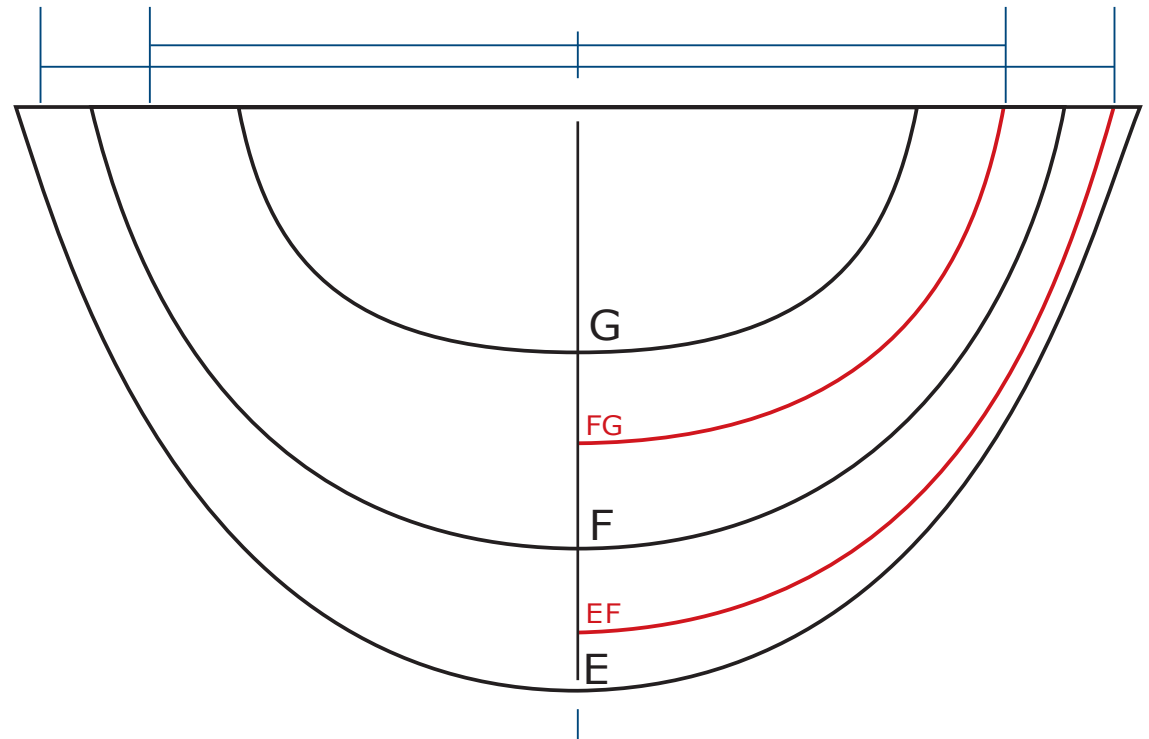

When these plans are printed the box around this text should measure 100x20mm. If it doesn't try altering the print settings and scale the printing to 102% for example.

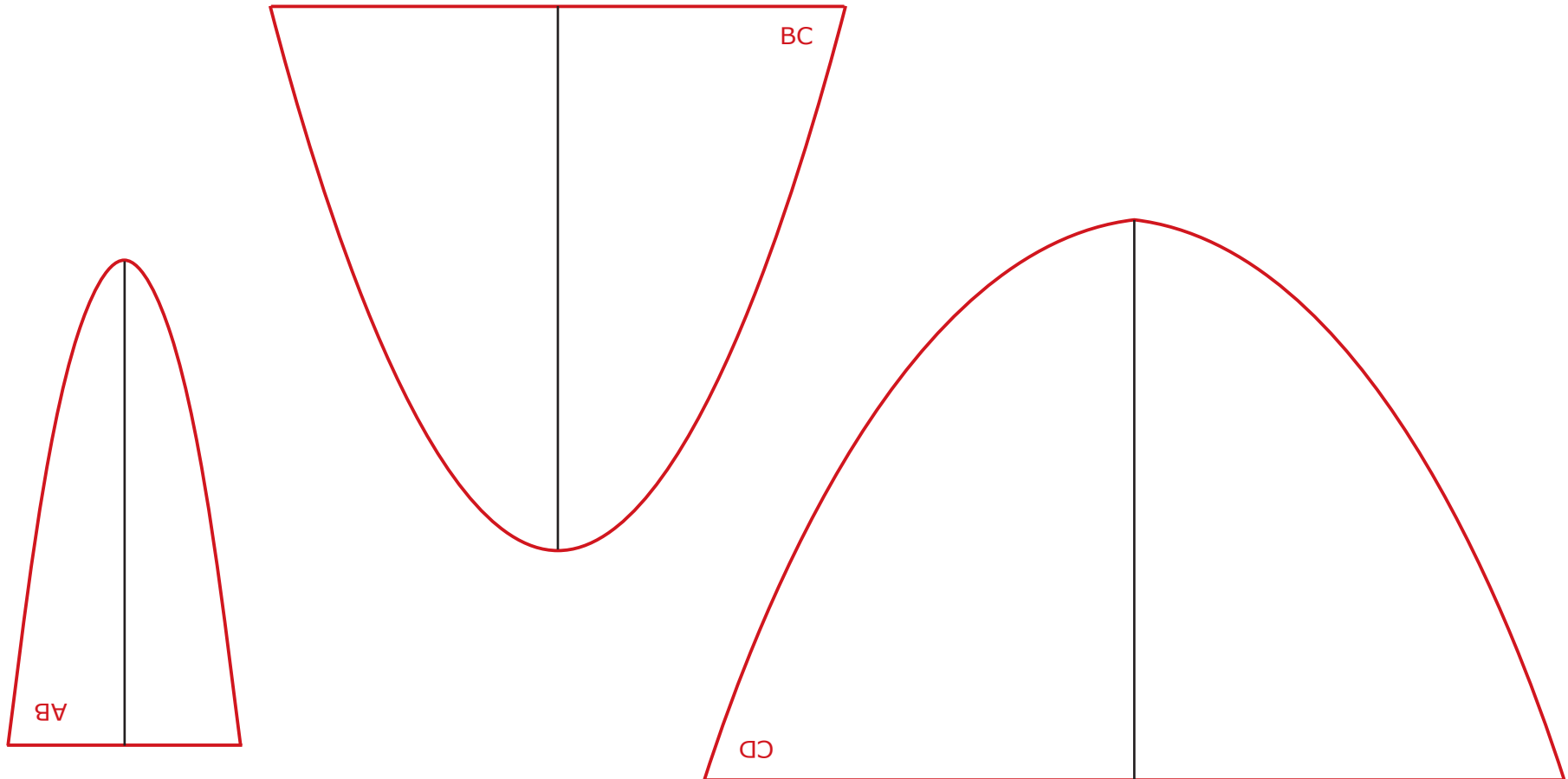

When these plans are printed the box around this text should measure 100x20mm. If it doesn't try altering the print settings and scale the printing to 102% for example.

